

Plug-In Attenuator/Switch

PAS-2

50Ω Bi-Phase

10 to 1000 MHz

Maximum Ratings

| | |
|-----------------------|----------------|
| Operating Temperature | -55°C to 100°C |
| Storage Temperature | -55°C to 100°C |
| Control Current | 30mA |

Pin Connections

| | |
|-------------|------------------|
| INPUT | 1 |
| OUTPUT | 8 |
| CONTROL | 3,4 [^] |
| GROUND | 2,5,6,7 |
| CASE GROUND | 2,5,6,7 |

[^]pins must be connected together externally

Outline Drawing

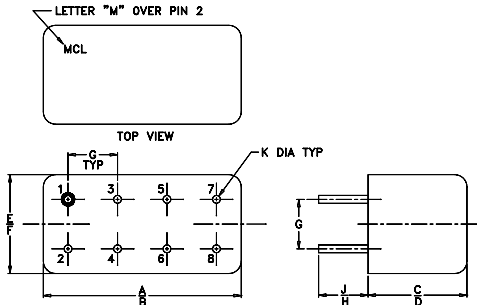

Outline Dimensions (inch/mm)

| | | | | | | | |
|-------|-------|------|-------|------|-------|-------|--|
| A | B | C | D | E | F | | |
| .770 | .800 | .385 | .400 | .370 | .400 | | |
| 19.56 | 20.32 | 9.78 | 10.16 | 9.40 | 10.16 | | |
| G | H | J | K | | | wt | |
| .200 | .20 | .14 | .031 | | | grams | |
| 5.08 | 5.08 | 3.56 | 0.79 | | | 5.2 | |

Features

- wideband, 10 to 1000 MHz
- hermetic case
- high in-out isolation
- excellent amplitude and phase unbalance

Applications

- bi-phase modulator
- electronic attenuator
- military hi-rel application

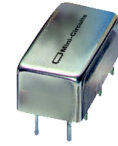

CASE STYLE: A01

PRICE: \$50.20 ea. QTY (1-9)

Attenuator/Switch Electrical Specifications

| FREQUENCY (MHz) | INSERTION LOSS (dB) ±20 mA | MAX. INPUT PWR (dBm) ±20 mA | IN-OUT ISOLATION (dB) 0 mA | | | BI-PHASE X (±20 mA) Typ. | | | |
|-----------------|----------------------------|-----------------------------|----------------------------|----|----|--------------------------|---------------------------------|-------------|-------------|
| | | | L | M | U | Δ AMP (dB) | Phase (deg) deviation from 180° | Total Range | Total Range |
| 10-1000 | DC-0.05 | 20 | 29 | 25 | 25 | 0.1 | 0.3 | 0.5 | 1.0 |

L = low range [f_L to $10 f_L$] M = mid range [$10 f_L$ to $f_U/2$] U = upper range [$f_U/2$ to f_U] m = mid band [$2f_L$ to $f_U/2$]

Performance specifications apply for input power up to 10 dB below stated 1dB compression.

suggested control port biasing configuration

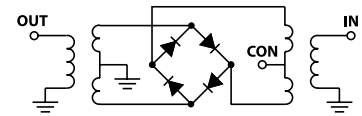
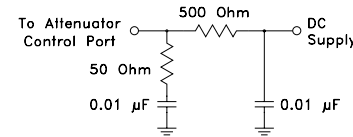

Typical Performance Data

| Freq. (MHz) | I. Loss (dB) at 20mA | ±Control Δ Amp (dB) | 20mA ΔPhase (deg.) | Isolation (dB) (in-out) (in-con) | | Input R. Loss (dB) | Control Current (mA) | Attenuation (dB) | | | Phase Δ ref at 15mA Ctrl (deg.) | | | Input VSWR | | | |
|-------------|----------------------|---------------------|--------------------|----------------------------------|---------|--------------------|----------------------|------------------|--------|---------|---------------------------------|--------|---------|------------|-----|-----|-----|
| | | | | 10 MHz | 500 MHz | | | 1000 MHz | 10 MHz | 500 MHz | 1000 MHz | 10 MHz | 500 MHz | 1000 MHz | | | |
| 10.0 | 3.50 | 0.025 | 0.01 | 180.00 | 70 | 47 | 12.3 | 0.0000 | 71.8 | 43.8 | 38.2 | -37.1 | 96.0 | 63.6 | 3.6 | 2.9 | 7.5 |
| 19.9 | 3.52 | 0.015 | 0.01 | 180.00 | 68 | 40 | 12.7 | 0.0003 | 63.7 | 44.2 | 38.1 | -34.3 | 93.2 | 62.4 | 3.6 | 2.9 | 7.5 |
| 39.7 | 3.61 | 0.008 | 0.01 | 179.90 | 67 | 35 | 12.6 | 0.0004 | 55.7 | 43.8 | 38.1 | -12.5 | 86.0 | 57.8 | 3.6 | 2.9 | 7.5 |
| 59.5 | 3.63 | 0.006 | 0.01 | 179.90 | 65 | 31 | 12.5 | 0.0016 | 51.2 | 43.3 | 38.1 | -8.5 | 80.1 | 52.8 | 3.6 | 2.8 | 7.4 |
| 79.3 | 3.66 | 0.006 | 0.01 | 179.90 | 64 | 29 | 12.5 | 0.0057 | 45.4 | 41.1 | 36.8 | -4.6 | 55.5 | 35.7 | 3.6 | 2.8 | 7.3 |
| 86.7 | 3.68 | 0.006 | 0.01 | 179.90 | 63 | 28 | 12.5 | 0.0105 | 41.5 | 38.6 | 35.6 | -1.2 | 42.6 | 23.4 | 3.5 | 2.8 | 7.1 |
| 99.1 | 3.73 | 0.006 | 0.01 | 179.90 | 62 | 27 | 12.4 | 0.0161 | 38.3 | 36.0 | 33.7 | 1.5 | 34.4 | 12.9 | 3.5 | 2.8 | 6.9 |
| 163.5 | 3.95 | 0.006 | 0.01 | 179.80 | 58 | 23 | 12.3 | 0.0286 | 33.9 | 31.8 | 30.1 | 3.6 | 24.5 | 0.6 | 3.4 | 2.7 | 6.6 |
| 237.7 | 4.03 | 0.007 | 0.01 | 179.70 | 55 | 20 | 12.1 | 0.0437 | 30.3 | 28.4 | 27.1 | 4.3 | 20.7 | -5.6 | 3.3 | 2.6 | 6.2 |
| 314.4 | 4.05 | 0.008 | 0.01 | 179.37 | 52 | 18 | 12.0 | 0.0734 | 26.2 | 24.4 | 23.2 | 5.1 | 16.3 | -9.9 | 3.1 | 2.4 | 5.6 |
| 391.2 | 4.23 | 0.012 | 0.02 | 179.60 | 50 | 17 | 12.1 | 0.1029 | 23.6 | 21.8 | 20.8 | 5.0 | 14.4 | -11.4 | 2.9 | 2.3 | 5.2 |
| 467.9 | 4.36 | 0.017 | 0.04 | 179.60 | 48 | 17 | 12.3 | 0.1510 | 20.7 | 19.1 | 18.2 | 5.0 | 12.8 | -11.9 | 2.7 | 2.1 | 4.7 |
| 500.1 | 4.38 | 0.021 | 0.04 | 179.60 | 47 | 17 | 12.4 | 0.2540 | 17.1 | 15.6 | 15.1 | 4.6 | 10.4 | -11.1 | 2.4 | 1.8 | 4.0 |
| 542.1 | 4.48 | 0.027 | 0.06 | 179.50 | 46 | 17 | 12.5 | 0.3743 | 14.6 | 13.3 | 13.1 | 4.3 | 9.0 | -9.9 | 2.1 | 1.6 | 3.6 |
| 618.9 | 4.63 | 0.040 | 0.10 | 179.50 | 44 | 18 | 12.6 | 0.6438 | 11.5 | 10.6 | 10.8 | 3.5 | 6.9 | -7.5 | 1.7 | 1.3 | 3.1 |
| 695.6 | 4.90 | 0.053 | 0.13 | 179.60 | 43 | 20 | 12.1 | 0.9350 | 9.7 | 9.1 | 9.6 | 3.0 | 5.4 | -6.0 | 1.5 | 1.2 | 2.9 |
| 772.3 | 5.02 | 0.064 | 0.16 | 179.38 | 41 | 23 | 10.8 | 1.7496 | 7.2 | 7.2 | 8.2 | 2.0 | 3.6 | -3.6 | 1.2 | 1.1 | 2.7 |
| 846.6 | 5.51 | 0.073 | 0.16 | 179.70 | 41 | 21 | 9.1 | 2.6537 | 5.5 | 5.9 | 7.3 | 1.3 | 1.9 | -1.8 | 1.2 | 1.3 | 2.7 |
| 923.3 | 6.21 | 0.087 | 0.21 | 179.80 | 40 | 17 | 7.5 | 7.3045 | 4.3 | 4.9 | 6.7 | 0.5 | 0.6 | -0.7 | 1.4 | 1.5 | 2.6 |
| 1000.0 | 7.06 | 0.093 | 0.36 | 180.40 | 40 | 14 | 6.3 | 15.1437 | 3.6 | 4.5 | 6.4 | 0.1 | 0.1 | -0.1 | 1.5 | 1.6 | 2.6 |

